

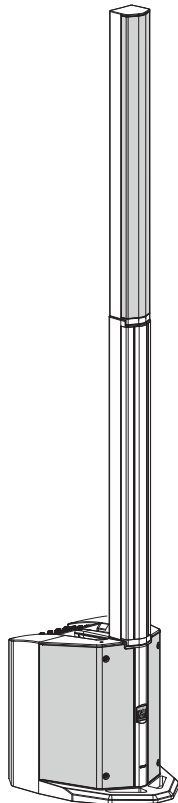

# LN™ 1063 Column ARRAY



---

## Specifications



### FCC/ICES Compliancy Statement

This device complies with Part 15 of the FCC rules and Industry Canada license-exempt RSS Standard(s). Operation is subject to the following two conditions: (1) this device may not cause harmful interference, and (2) this device must accept any interference received, that may cause undesired operation.

Le présent appareil est conforme aux CNR d'Industrie Canada applicables aux appareils radio exempts de licence. L'exploitation est autorisée aux deux conditions suivantes: (1) l'appareil ne doit pas produire de brouillage, et (2) l'utilisateur de l'appareil doit accepter tout brouillage radioélectrique subi, même si le brouillage est susceptible d'en compromettre le fonctionnement.

Warning: Changes or modifications to the equipment not approved by Peavey Electronics Corp. can void the user's authority to use the equipment.

Note – This equipment has been tested and found to comply with the limits for a Class B digital device, pursuant to Part 15 of the FCC Rules. These limits are designed to provide reasonable protection against harmful interference in a residential installation. This equipment generates, uses, and can radiate radio frequency energy and, if not installed and used in accordance with the instructions, may cause harmful interference to radio communications. However, there is no guarantee that interference will not occur in a particular installation. If this equipment does cause harmful interference to radio or television reception, which can be determined by turning the equipment off and on, the user is encouraged to try and correct the interference by one or more of the following measures.

- Reorient or relocate the receiving antenna.
- Increase the separation between the equipment and receiver.
- Connect the equipment into an outlet on a circuit different from that to which the receiver is connected.
- Consult the dealer or an experienced radio/TV technician for help.

### Caution

The equipment complies with FCC radiation exposure limits set forth for an uncontrolled environment.



Features and specifications are subject to change without notice.

Peavey Electronics Corporation • 711 A Street • Meridian, MS 39301

(601) 483-5365 • FAX (601) 486-1278 • [www.peavey.com](http://www.peavey.com)

## **FCC Radiation Exposure Statement**

This equipment complied with FCC radiation exposure limits set forth for an uncontrolled environment. This equipment should be installed and operated with minimum distance 20cm between the radiator & your body.

## **IC Radiation Exposure Statement**

This equipment complies with IC radiation exposure limits set forth for an uncontrolled environment. The antenna should be installed and operated with minimum distance of 20 cm between the radiator and your body. This transmitter must not be co-located or operating in conjunction with any other antenna or transmitter.

Cet appareil est conforme aux limites d'exposition aux rayonnements de la IC pour un environnement non contrôlé. L'antenne doit être installé de façon à garder une distance minimale de 20 centimètres entre la source de rayonnements et votre corps. L'émetteur ne doit pas être colocalisé ni fonctionner conjointement avec à autre antenne ou autre émetteur.

## LN™1063

Column Array Powered Speaker System

Congratulations on purchasing the Peavey LN™1063 Column Array Powered Speaker System. This compact, portable and powerful system is a perfect solution for the weekend warrior, singer songwriter or DJ.

### FEATURES:

- Bluetooth audio input for streaming music from any Bluetooth device
- 6 Channel mixer
- 2 Combi inputs with Guitar Channel selectability
- 2 Onboard guitar channels
- 1 1/4" Stereo input channel
- 3.5 mm input
- Mix out for additional units
- Satellite speaker carrying bag included
- 500 Watts maximum power
- 120 dB maximum SPL
- Frequency response 55 Hz - 18 kHz

### Description:

The LN™1063 is a compact, powerful, lightweight and low profile portable column-array. Utilizing 500 watts of potential maximum power, the unit contains 6 2.75" custom drivers for the mid-high column and a custom 8" driver for the subwoofer. Completely self contained, the unit has no visible cables in mono operation. Its clean design is well suited for applications where speakers should be heard and not seen. Coming in at 10lbs lighter than our nearest competitor, the LN1063 is extremely easy to carry: an entire PA system that can be moved by one person in one trip.

The satellite speakers feature rugged housing and quick attachment design. The subwoofer is both durable and lightweight.

The onboard mixer features 2 combo inputs, each with the option of selecting a guitar input, making this the first column array designed specifically with the acoustic guitar performer in mind. Two additional media channels feature stereo 1/4" inputs and streaming audio Bluetooth in. Perfect for church, convention, DJ or club applications, the LN1063 offers the best-in-class feature-to-value and performance in the industry.



#### Installation Note:

This unit must have the following clearances from any combustible surface: top: 8", sides: 12", back: 12"

## Top Panel

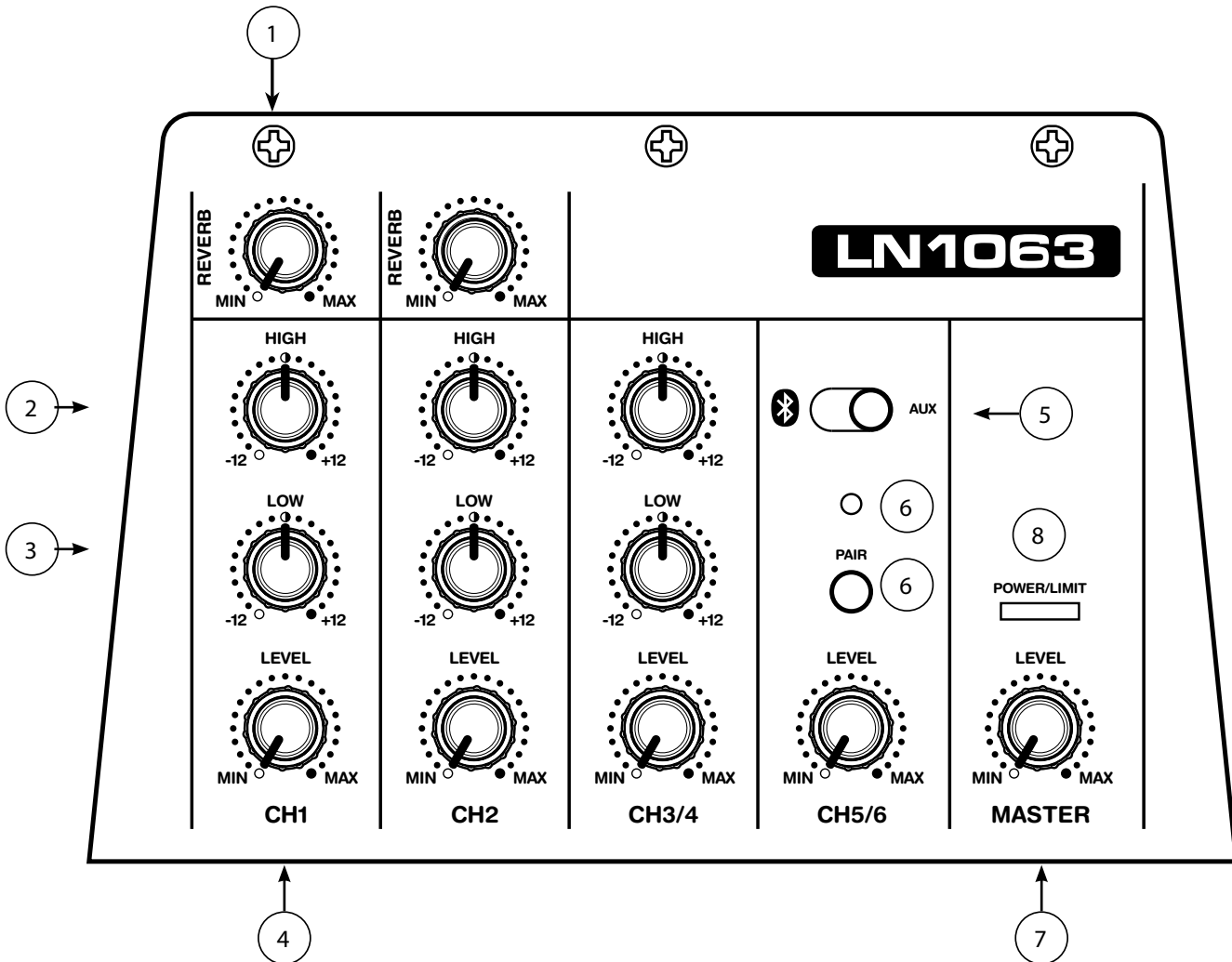

### (1) Channel Reverb Control

This knob controls the amount of reverb for the corresponding channel (channels 1-2).

### (2) High EQ (treble) Control

This is an active tone control (shelving type: +/-15dB) that varies the level of the high frequency range.

### (3) Low EQ (Bass) Control

This is an active tone control (shelving type: +/-15dB) that varies the level of the low frequency range.

### (4) Channel Level

This knob controls the level of the specific channels audio in the mix.

### (5) Bluetooth/Aux Input Switch

This switch selects the audio source for channel 5/6. Push to the left to route the Bluetooth signal to the channel. Push to the right to route the Aux input from the 3.5mm Stereo Jack (12) to the channel.

### (6) Pair Button/LED

This button is used to pair a phone or Bluetooth source to the speaker. The LED will indicate if it is in discovery mode (blinking) or paired to a Bluetooth source (solid). Pushing the button turns on the Bluetooth and places the speaker in discovery mode (blinking LED). Now you should be able to connect any Bluetooth audio source to the

speaker. To disconnect, press the button again, it will turn the Bluetooth off (LED dark).

### (7) Master Level

Use to control the overall volume of the speaker system.

### (8) Power/Limit LED

The Power/Limit LED will illuminate blue when there is power applied to the speaker and the power switch (14) is in the "on" position. It will turn RED when the system has reached its maximum output.

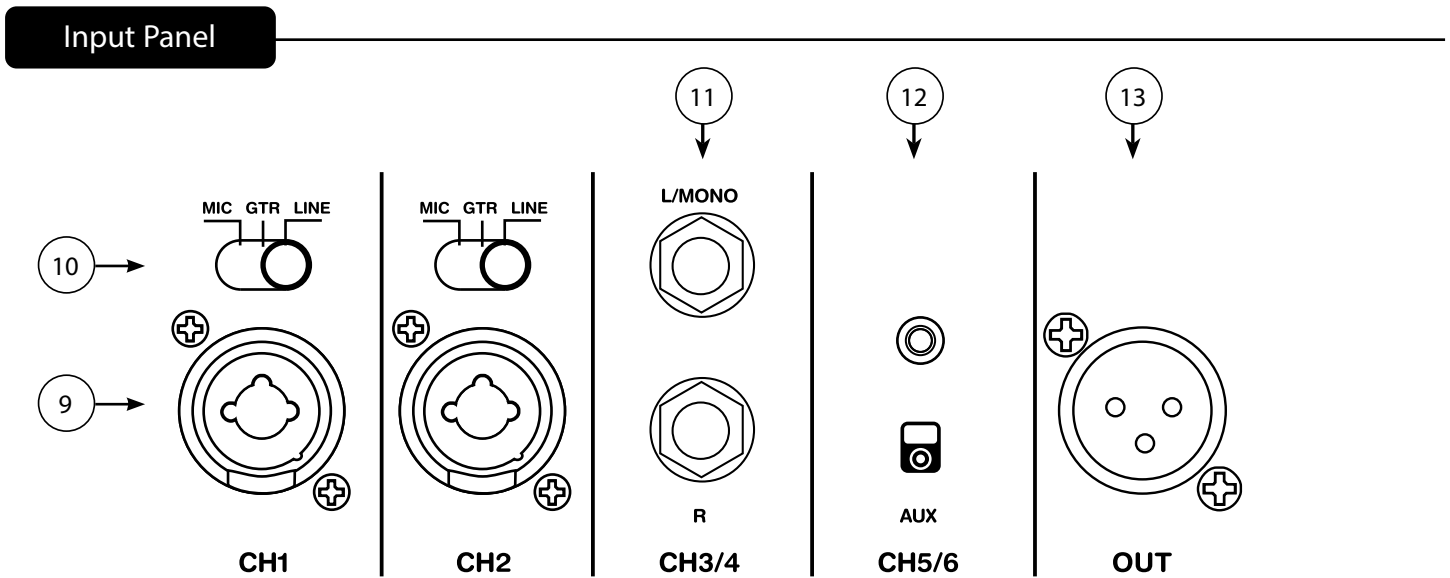

### (9) XLR Mic Input (Ch 1&2)

Use this XLR connector to connect a microphone to the LN1063 mixer.

### (10) Input Select Switch (Ch 1&2)

The Power/Limit LED will illuminate blue when there is power applied to the speaker and the power switch (14) is in the "on" position. It will turn RED when the system has reached its maximum output.

### (11) 1/4" Stereo Inputs (Ch 3&4)

- Channels 3 and 4 are a stereo pair of 1/4" jacks (TRS) that can be used for a stereo or mono line level source. If only one jack (L/Mono) is used, it behaves as a mono source. Once both jacks are connected, it becomes a stereo source; 3 is Left and 4 is Right.

### (12) 3.5mm Stereo Inputs (Ch 5&6)

Channels 5 and 6 is a stereo 3.5mm jack that can accept a stereo line input from the output of an MP3 player, phone or other similar device.

### (13) XLR Line Output

This is a non-powered XLR output at line level that can be used to link systems together or feed additional speakers.

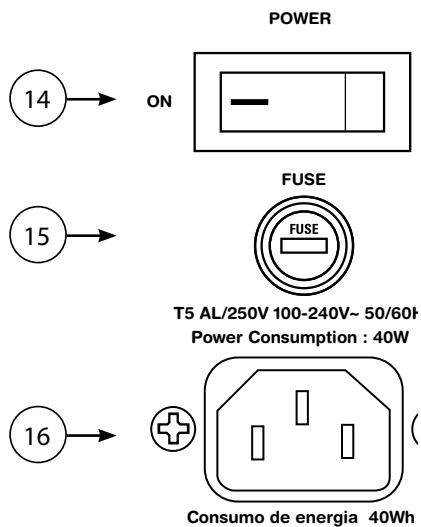

#### (14) Power Switch

The power switch is used to turn the speaker on and off

#### (15) Fuse

This is the main safety fuse for the AC line voltage. Only replace with a fuse of the exact type and rating. If the fuse continues to fail, do not replace the fuse again. Take the unit to an authorized Peavey service center.

#### (16) AC Power Inlet

 This is the receptacle for an IEC line cord, which provides AC power to the unit. Connect the line cord to this connector to provide power to the unit. Damage to the equipment may result if improper line voltage is used. (See line voltage marking on unit).

 Never break off the ground pin on any equipment. It is provided for your safety. If the outlet used does not have a ground pin, a suitable grounding adapter should be used and the third wire should be grounded properly. To prevent risk of shock or fire hazard, always make sure that the amplifier and all associated equipment is properly grounded.

# PARTS

## What is in the Box

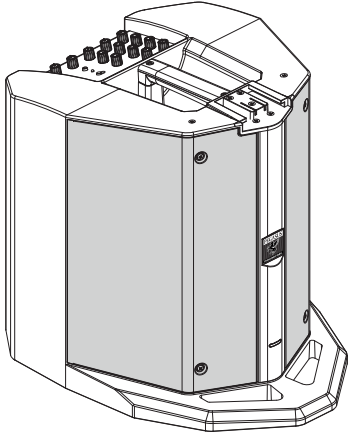

Subwoofer Component\*1

User Guide, Safety Instructions  
Warranty Information Booklet

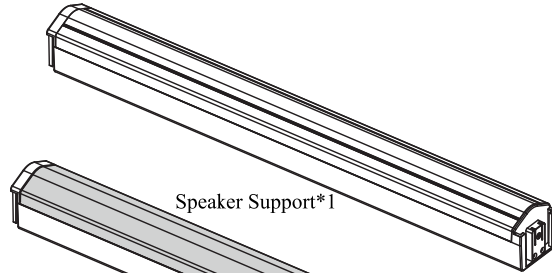

Speaker Support\*1

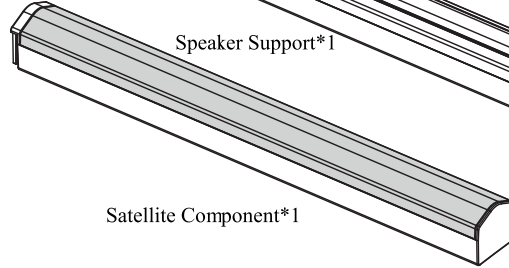

Satellite Component\*1

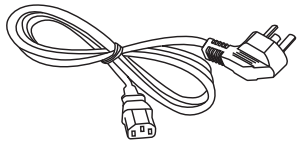

Power Cable\*1

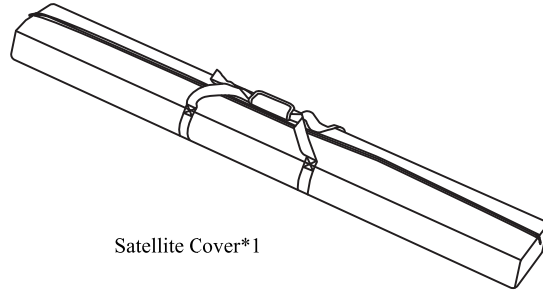

Satellite Cover\*1

## Optional Accessoires

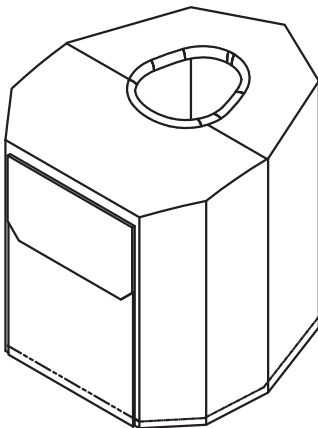

T1 Carry Bag



# INSTALLATION

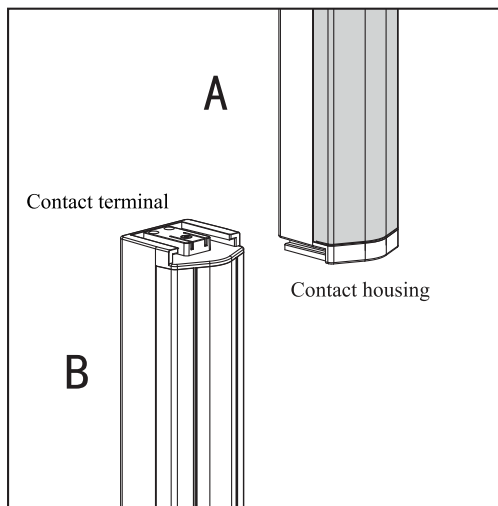
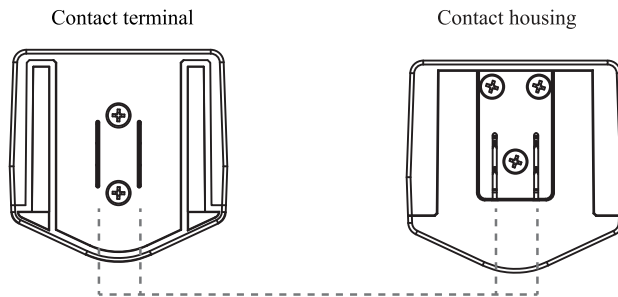
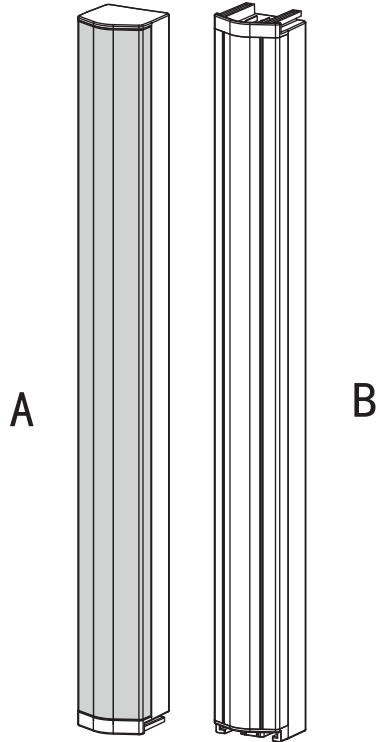

This housing guarantees the transmission of the audio signal among each component. Cables are not required in this case.

# INSTALLATION

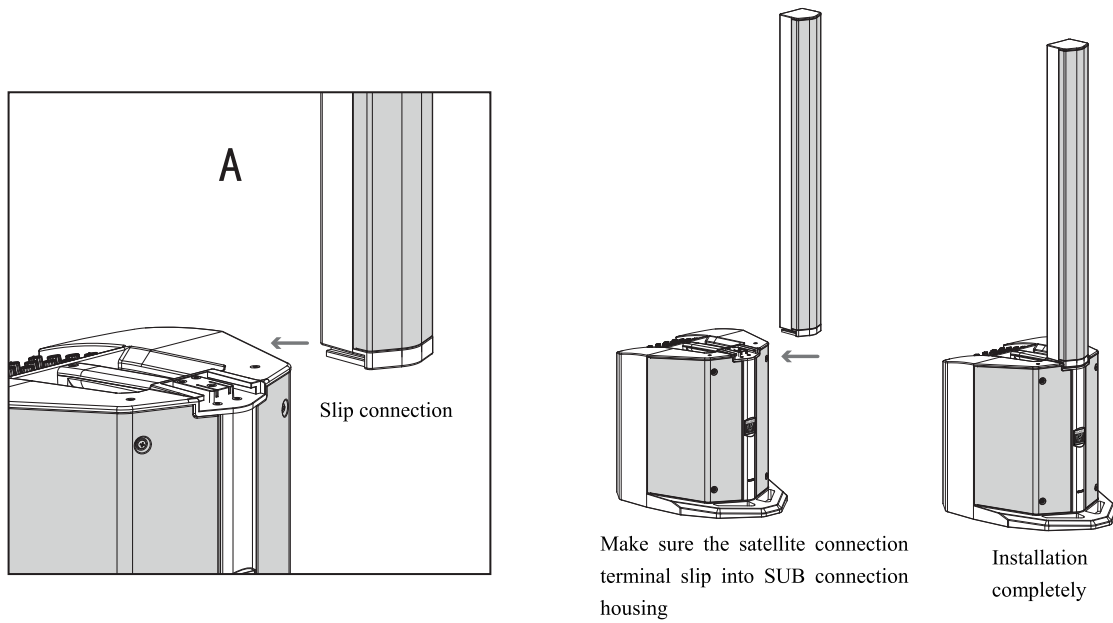

## Smaller audiences

- Intimate acoustic performances
- Music playback
- Presentations
- Speeches

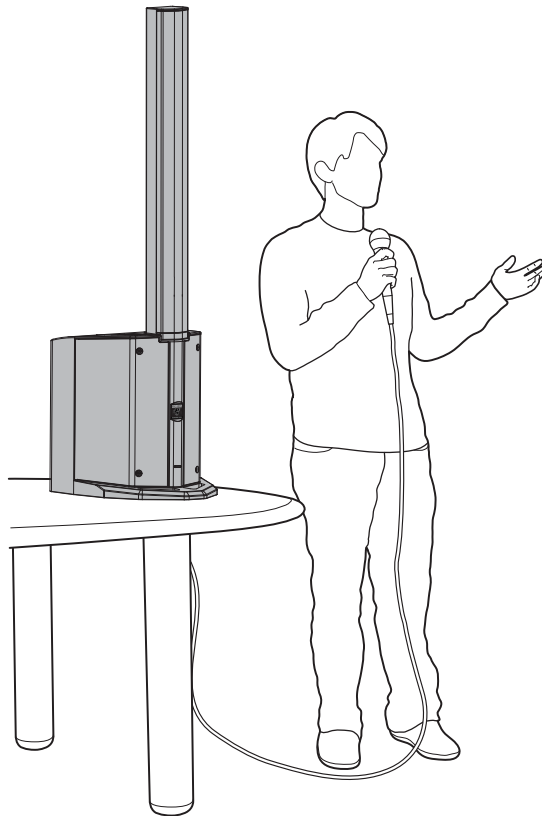
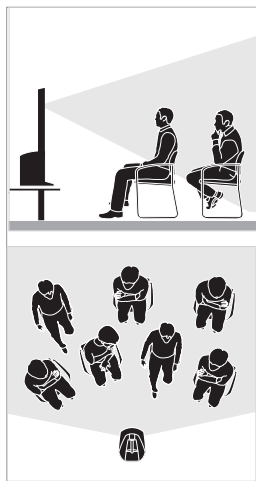

Please slip satellite component contact terminal into subwoofer contact housing.  
Attention, please make sure the connection completely.

# INSTALLATION

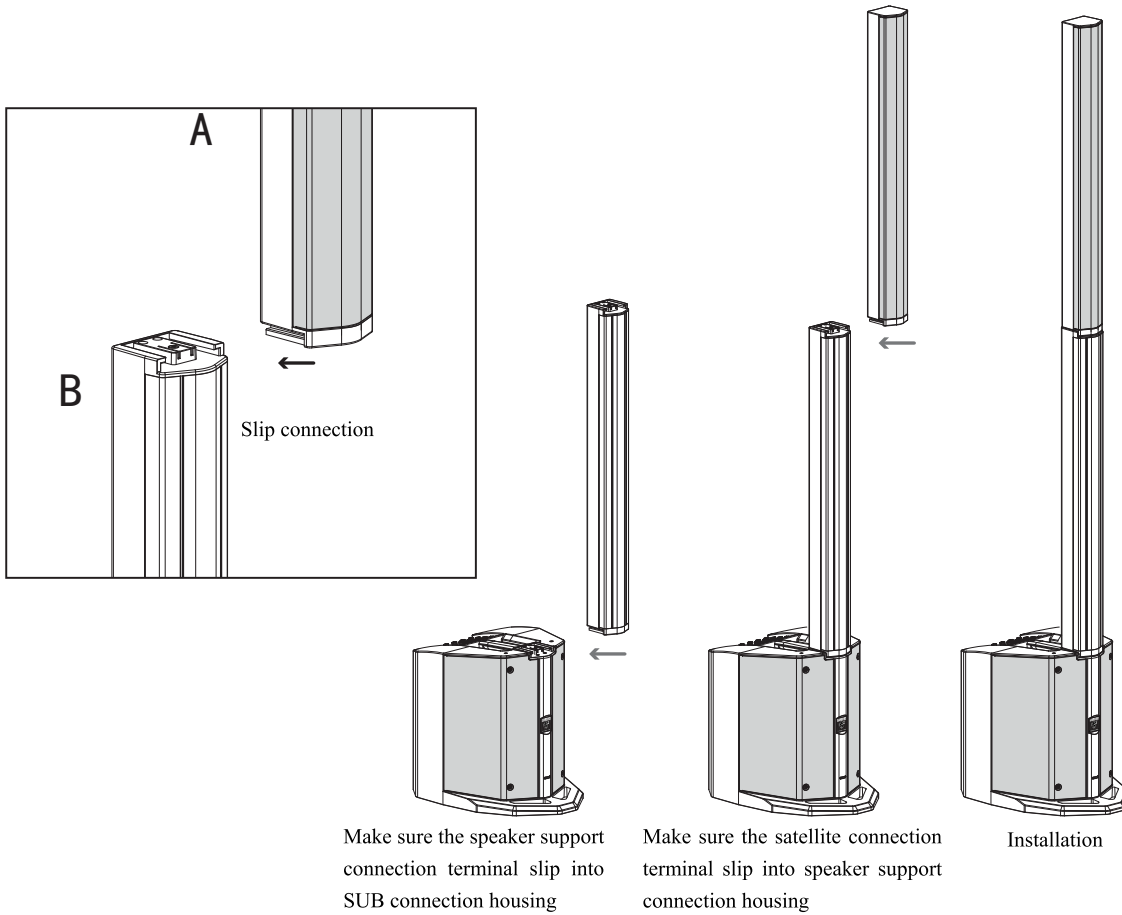

## Larger audiences

- Musical performances
- Auditorium/coffee house
- DJ events
- Announcements larger spaces

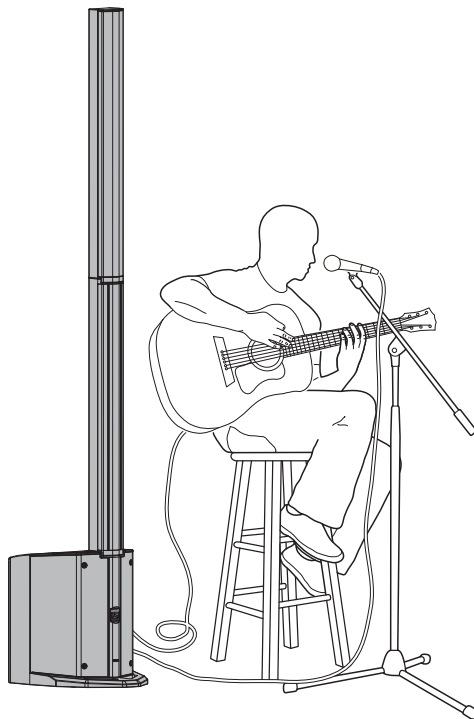
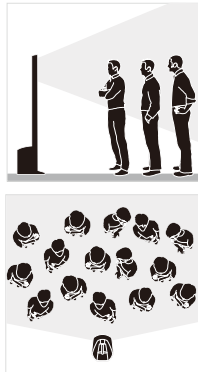

Please slip speaker support contact terminal into subwoofer contact housing firstly, and then slip satellite component contact terminal into speaker support contact housing.

Attention, please make sure the connection completely.

## LN™ 1063 Specifications

Channel 1-2 Input	Mic/Line/Guitar XLR and 1/4-inch TRS (balanced)
Channel 3 Left/Mono Input	Mono/Stereo 1/4-inch TRS (unbalanced)
Channel 4 Right Input.	Mono/Stereo 1/4-inch TRS (unbalanced)
Channel 5 Input	Stereo 3.5mm TRS (unbalanced)
Mix Out	+4dBu XLR (balanced)
Power/Clip LED	Blue/Red
Peak Power	500 Watts
Frequency Response.	55-18kHz
Max Output SPL	120 dB
Upper Column (speakers) Column Speaker.	6 x 2.75" drivers
Weight	5.17lbs. (2.3 kgs)
Dimensions	32.1 x 3.25 x 3.25 inches 815 x 82.55 x 82.55mm length x width x height
Lower Column (no speakers)	
Weight	2.53 lbs. (1.15 kgs)
Dimensions	32.63 x 3.25 x 3.25 inches 829 x 82.55 x 82.55 mm length x width x height
Sub Speaker	8" woofer, 1.5" voice coil
Sub/Mixer Weight	20.4 lbs. (9.25 kgs)
Sub/Mixer Dimensions	16 x 13.5 x 17 inches 406 x 343 x 432 mm length x width x height
Power Input (switchable)	100-120V, 50/60Hz, 40 W 220-240V, 50/60Hz, 40 W



[www.peavey.com](http://www.peavey.com)

Warranty registration and information for U.S. customers available online at  
[www.peavey.com/warranty](http://www.peavey.com/warranty)  
or use the QR tag below



Features and specifications subject to change without notice.

Peavey Electronics Corporation 5022 Hartley Peavey Drive Meridian, MS 39305 (601) 483-5365 FAX (601) 486-1278



Logo referenced in Directive 2002/96/EC Annex IV  
(OJ(L)37/38,13.02.03 and defined in EN 50419: 2005  
The bar is the symbol for marking of new waste and  
is applied only to equipment manufactured after  
13 August 2005