

# COLOrband PiX™

Mini

## User Manual

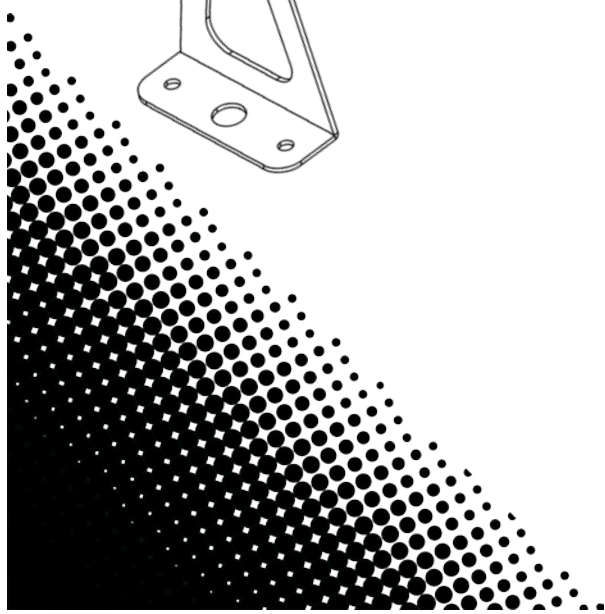
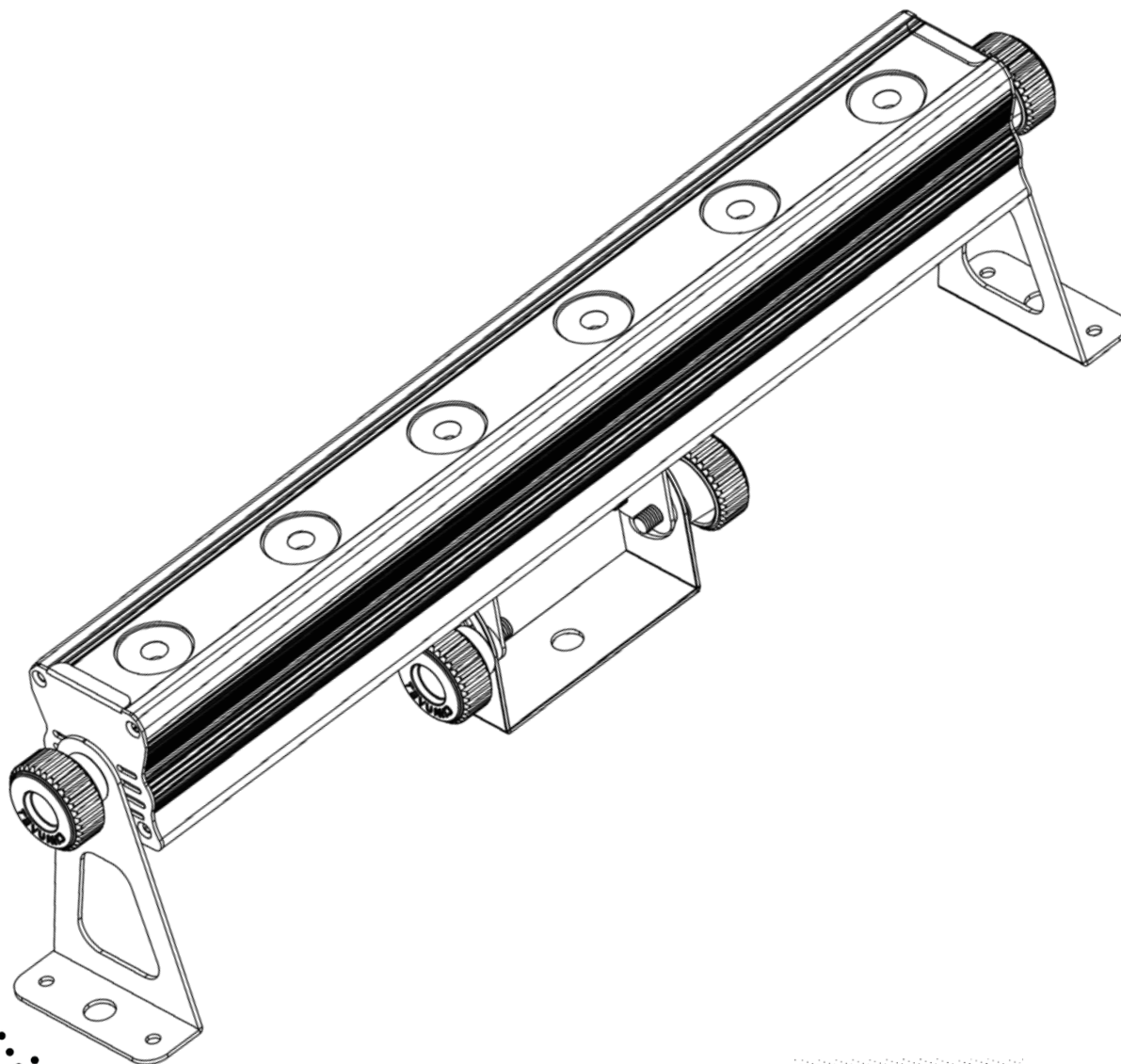

**CHAUVET®**  
*Value • Innovation • Performance*  
It's **Green** Thinking.™

---

# TABLE OF CONTENTS

<b>1. Before You Begin</b> .....	<b>3</b>
What Is Included .....	3
Unpacking Instructions .....	3
Claims .....	3
Text Conventions .....	3
Icons .....	3
Document Information .....	3
Product at a Glance.....	4
Safety Notes .....	4
<b>2. Introduction</b> .....	<b>5</b>
Product Overview .....	5
Product Dimensions .....	6
<b>3. Setup</b> .....	<b>7</b>
AC Power .....	7
Fuse Replacement.....	7
Power Linking .....	8
Mounting .....	9
Orientation .....	9
Rigging .....	9
CBB-6 Instructions .....	10
<b>4. Operation</b> .....	<b>11</b>
Control Panel Operation .....	11
Menu Map .....	11
Configuration (DMX).....	12
DMX Personalities and Starting Address.....	12
Sectional Control.....	12
DMX Channel Assignments and Values.....	13
7-CH.....	13
3-CH.....	13
4-CH.....	13
6-CH.....	14
9-CH.....	14
18CH.....	15
Configuration (Standalone).....	16
Static Color Mode .....	16
Automatic Mode .....	16
Custom Static Color Mode.....	16
Master/Slave Mode .....	17
<b>5. Maintenance</b> .....	<b>18</b>
Product Maintenance .....	18
Contact Us .....	19
Returns .....	19
<b>6. Technical Specifications</b> .....	<b>20</b>

# 1. BEFORE YOU BEGIN

## What Is Included

- 1 x COLORband PiX™ Mini
- 1 x Power Cord
- 2 x L-Brackets
- 1 x Warranty Card
- 1 x Quick Reference Guide

## Unpacking Instructions

Immediately upon receipt, carefully unpack the product and check the container to make sure you have received all the parts indicated above in good condition.

## Claims



If the box or the contents (the product and included accessories) appear damaged from shipping, or show signs of mishandling, upon receipt notify the carrier immediately, not CHAUVET®. Failure to do so in a timely manner may invalidate your claim with the carrier. In addition, keep the container and all the packing material for inspection.

For other issues such as missing components or parts, damage not related to shipping, or concealed damage, file a claim with CHAUVET® within 7 days of receiving the product.

## Text Conventions

Convention	Meaning
1-512	A range of values
50/60	A set of values of which only one can be chosen
<b>Settings</b>	A menu option not to be modified
<b>Menu &gt; Settings</b>	A sequence of menu options to be followed
<b>&lt;ENTER&gt;</b>	A key to be pressed on the product's control panel
<b>ON</b>	A value to be entered or selected

## Icons

Icon	Meaning
	Critical installation, configuration, or operation information. Failure to comply with this information may keep the product from working, damage it, or cause harm to the user.
	Important installation or configuration information. Failure to comply may prevent correct function.
	Useful information.

## Document Information

The information and specifications contained in this document are subject to change without notice. CHAUVET® assumes no responsibility or liability for any errors or omissions that may appear in this manual. CHAUVET® reserves the right to update the existing document or to create a new document to correct any errors or omissions.

You can download the latest version of this document from [www.chauvetlighting.com](http://www.chauvetlighting.com).

© Copyright 2013 CHAUVET®. All rights reserved.

Electronically published by CHAUVET® in the United States of America

Author	Date	Editor	Date
A. Leon	06/07/13	T. Yeago	06/17/13

## Product at a Glance

Use on Dimmer	X	Auto Programs	P
Outdoor Use	X	Auto-ranging Power Supply	P
Sound Activated	P	Replaceable Fuse	P
DMX	P	User Serviceable	X
Master/Slave	P	Duty Cycle	X

## Safety Notes

Please read the following Safety Notes carefully before working with the product. The Notes include important safety information about installation, usage, and maintenance.



- Always connect the product to a grounded circuit to avoid the risk of electrocution.
- Always disconnect the product from the power source before cleaning or replacing the fuse.
- Avoid direct eye exposure to the light source while the product is on.
- Make sure the power cord is not crimped or damaged.
- Never disconnect the product from power cord by pulling or tugging on the cord.
- If mounting the product overhead, always secure to a fastening device using a safety cable.
- Make sure there are no flammable materials close to the product when operating.
- Do not touch the product's housing when operating because it may be very hot.



- Always make sure that the voltage of the outlet to which you are connecting the product is within the range stated on the decal or rear panel of the product.
- The product is for indoor use only! (IP20) To prevent risk of fire or shock, do not expose the product to rain or moisture.
- Always install the product in a location with adequate ventilation, at least 20 in (50 cm) from adjacent surfaces.
- Be sure that no ventilation slots on the product's housing are blocked.
- Never connect the product to a dimmer.
- Make sure to replace the fuse with another of the same type and rating.
- Never carry the product from the power cord or any moving part. Always use the hanging/mounting bracket or the handles.
- The maximum ambient temperature (Ta) is 104° F (40° C). Do not operate the product at higher temperatures.
- In the event of a serious operating problem, stop using the product immediately.
- Never try to repair the product. Repairs carried out by unskilled people can lead to damage or malfunction. Please contact the nearest authorized technical assistance center.



- Keep this User Manual for future consultation. If you sell the product to another user, be sure that they also receive this document.

## 2. INTRODUCTION

### Product Overview

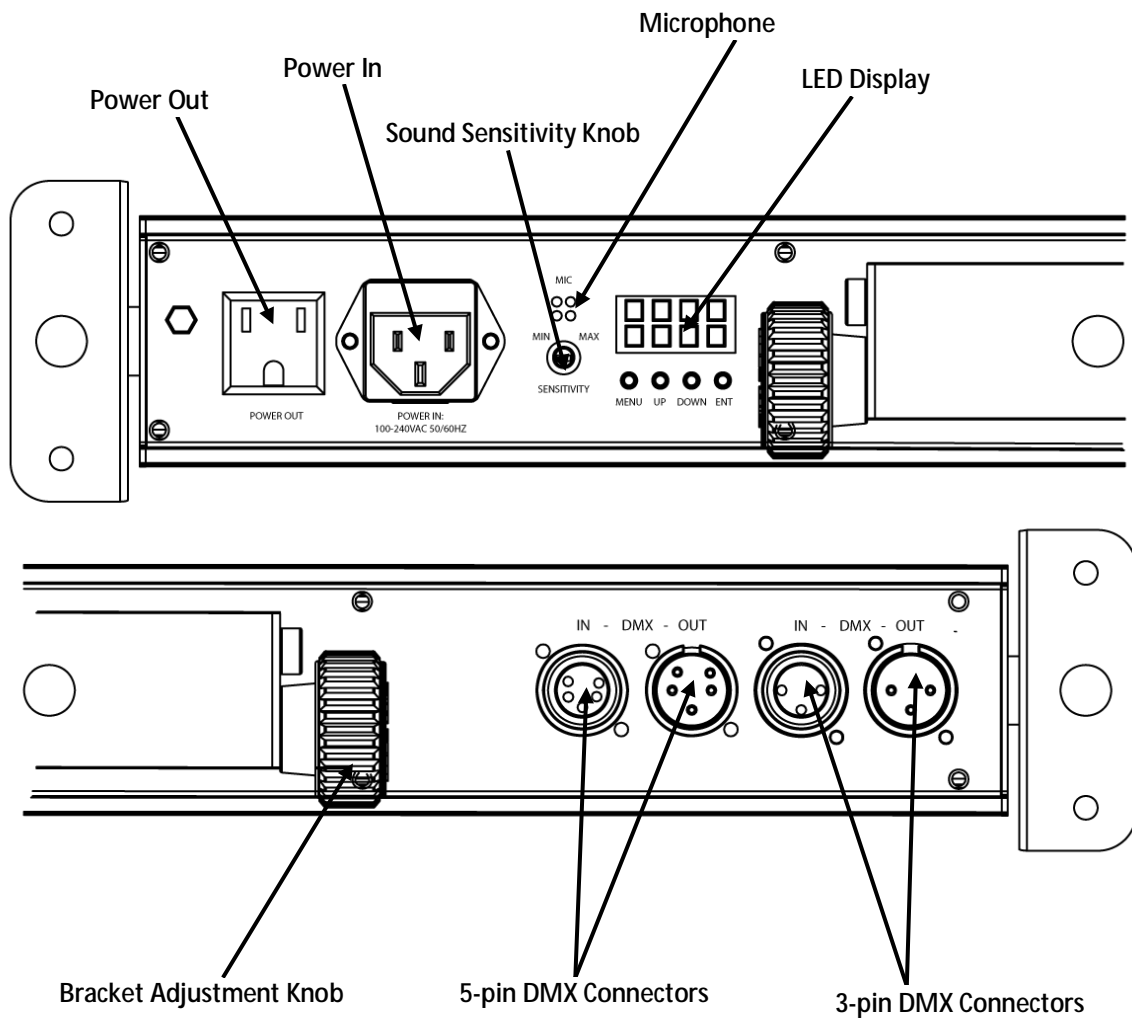

# Product Dimensions

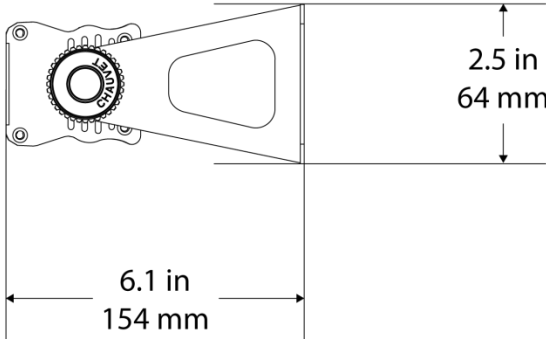
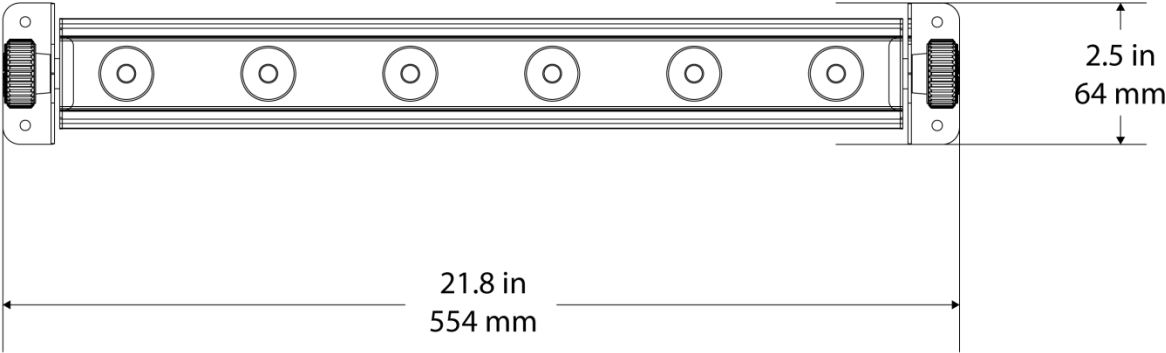

## 3. SETUP

**AC Power** The COLORband PiX™ Mini has an auto-ranging power supply and can work with an input voltage range of 100~240 VAC, 50/60 Hz.

To determine the product's power requirements (circuit breaker, power outlet, and wiring), use the current value listed on the label affixed to the product's back panel, or refer to the product's specifications chart. The listed current rating indicates the product's average current draw under normal conditions.



**Always connect the product to a protected circuit (circuit breaker or fuse). Make sure the product has an appropriate electrical ground to avoid the risk of electrocution or fire.**



**Never connect the product to a rheostat (variable resistor) or dimmer circuit, even if the rheostat or dimmer channel serves only as a 0% to 100% switch.**

### Fuse Replacement

Follow the instructions below to change the fuse, if necessary.



**Disconnect the product from the power outlet before replacing the fuse.**

1. Wedge the tip of a flat-head screwdriver into the slot of the fuse holder.
2. Pry the fuse holder out of the housing.
3. Remove the blown fuse from the holder and replace with a fuse of the exact same type and rating.
4. Insert the fuse holder back in place and reconnect power.

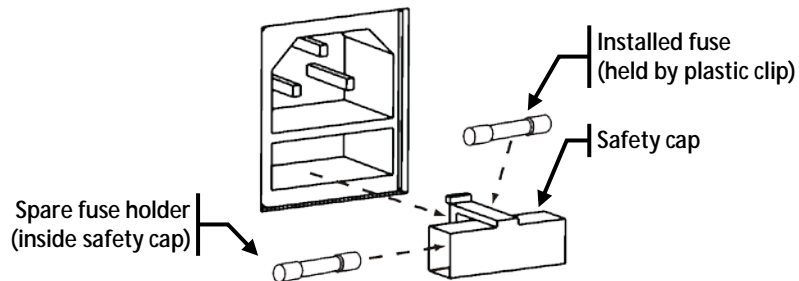

**The product does not ship with a spare fuse; however, the safety cap has room for a spare.**

**Power Linking** The product provides power linking via the IEC outlet located in the back of the unit.

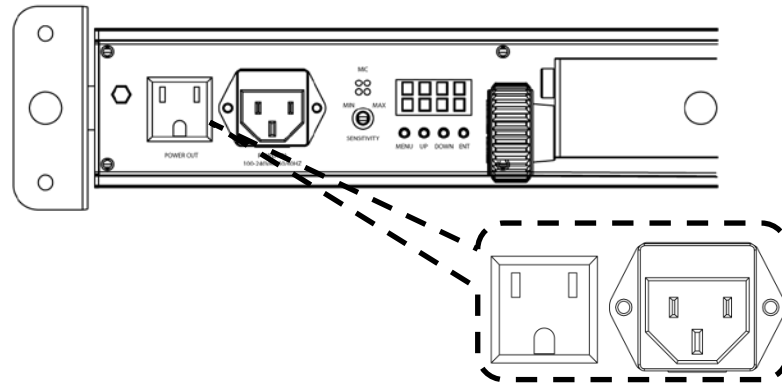

Power Linking Diagram

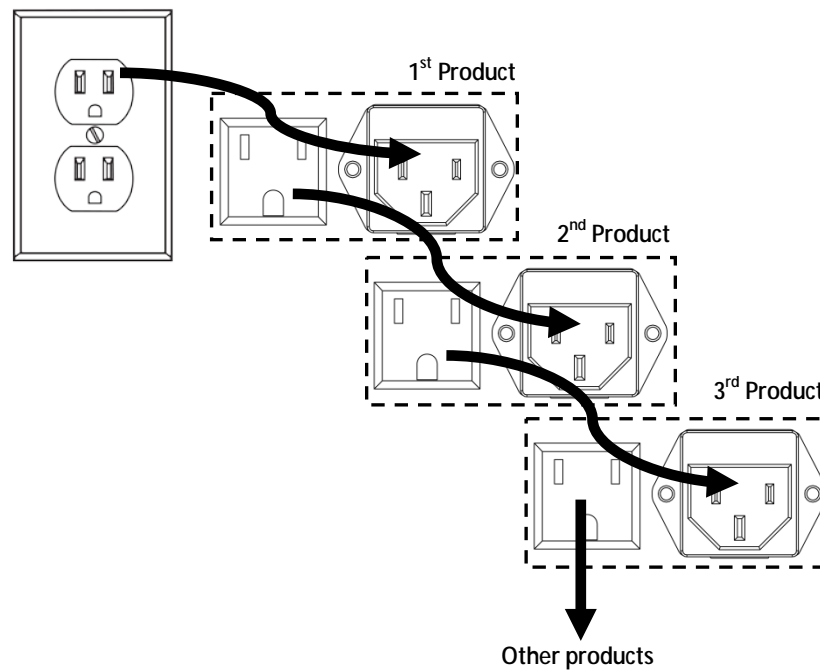

You can power link up to 20 COLORband PiX™ Mini units on 120 VAC or up to 35 COLORband PiX™ Mini units on 230 VAC.



The power linking diagram shown above corresponds to the North American version of the product ONLY! If using the product in other markets, you must consult with the local CHAUVET® distributor because power linking connectors and requirements may differ in your country or region.



---

**Mounting** Before mounting the product, read and follow the safety recommendations indicated in the [Safety Notes](#).

**Orientation** The COLORband PiX™ Mini may be mounted in any position; however, make sure adequate ventilation is provided around the product.

- Rigging**
- Before deciding on a location for the product, always make sure there is easy access to the product for maintenance and programming purposes.
  - Make sure that the structure or surface onto which you are mounting the product can support the product's weight. Please see the [Technical Specifications](#) for weight information.
  - When mounting the product overhead, always use a safety cable. Mount the product securely to a rigging point, whether an elevated platform or a truss.
  - When rigging the product onto a truss, use a mounting clamp of appropriate weight capacity.
  - When power linking multiple products, you must always consider the length of the power linking cable and mount the products close enough for the cable to reach.
  - The bracket adjustment knobs allow for directional adjustment when aiming the product to the desired angle. Only loosen or tighten the bracket knobs manually. Using tools could damage the knobs.
  - The mounting brackets also serve as floor supports/allow for surface mounting. When mounting the product on the floor, make sure that the product and cables are away from people and vehicles.
  - The CBB-6 bracket (sold separately) is fully compatible with the COLORband PiX™ Mini.

Mounting Diagram

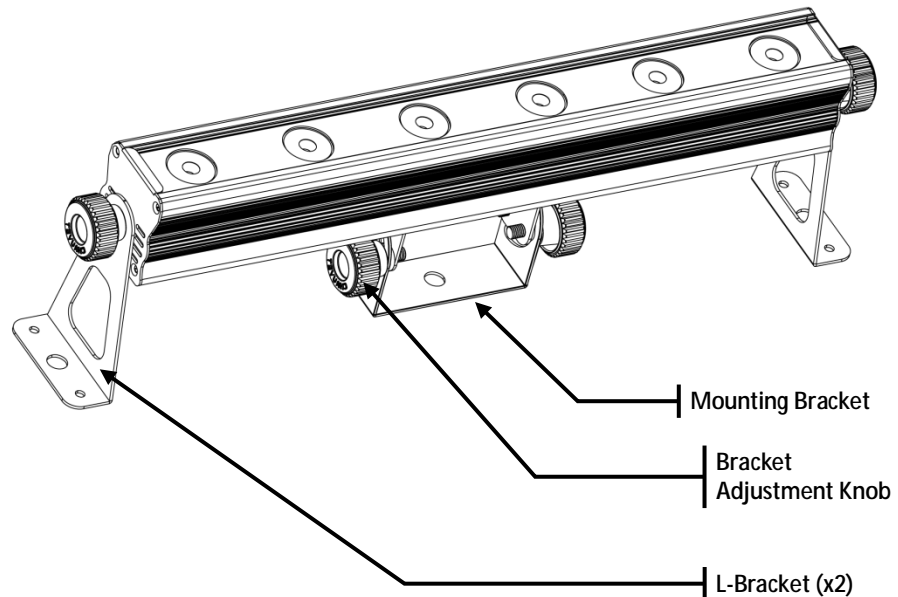

## CBB-6 Instructions

The CBB-6 works with the COLORband PiX™ Mini (shown below), COLORband PiX™, and most linear/strip lights.

### Basic Assembly

To assemble the CBB-6 bracket:

1. Unscrew the bracket adjustment knob on the light you wish to attach to the bracket.
2. Align the light to any of the small mounting holes on the CBB-6 (maximum 6 lights).
3. Reattach the bracket adjustment knob to the light.
4. Repeat up to a total of six times with a pair of CBB-6 brackets.

The final assembly should appear similar to this:

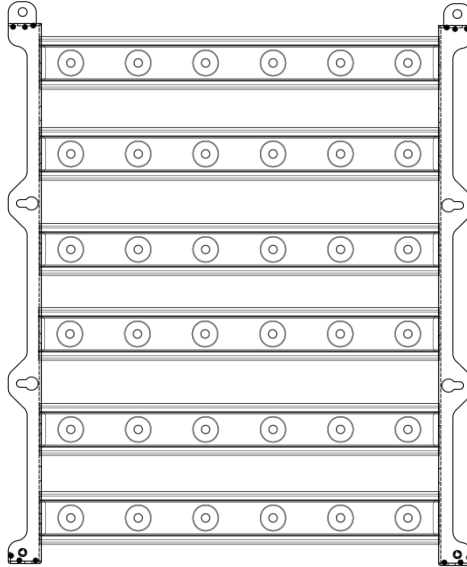

### Advanced Assembly Options

The CBB-6 is fully stackable. Use the included screws to attach another CBB-6 to the top of the bracket for additional rows of lights.

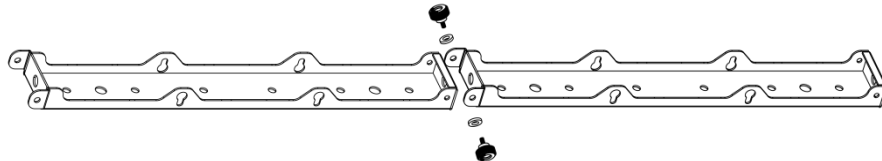

Do NOT connect more than two CBB-6 brackets vertically (for a maximum of 12 strip lights).



Before mounting the CBB-6 onto any structure, ensure that the structure onto which you are mounting the product on can support the total weight.



When rigging the product onto truss, you should use a mounting clamp with the appropriate weight capacity. The CBB-6 bracket has multiple 13-mm holes which are appropriate for this purpose.



CHAUVET® recommends the CLP-15 heavy-duty clamp (sold separately).

## 4. OPERATION

**Control Panel Operation** To access the control panel functions, use the four buttons located underneath the display.

Button	Function
<MENU>	Press to find an operation mode or to back out of the current menu option
<UP>	Press to scroll up the list of options or to find a higher value
<DOWN>	Press to scroll down the list of options or to find a lower value
<ENTER>	Press to activate a menu option or a selected value

Mode	Programming Steps	Description	
Static Colors	C--	C1	Red
		C2	Green
		C3	Blue
		C4	Cyan
		C5	Magenta
		C6	Yellow
		C7	White
Auto Programs	P--	P1	7-Color Switching
		P2	7-Color Fading
		P3	3-Color Switching
		P4	3-Color Fading
		P5	Chase Program
		P6	7-Color Sound Active
		P7	7-Color Sound Active Chase + Strobe
Program Speed	S--	S001-S100	Selects auto program speed
Slave Mode	SLA		Sets Slave Mode
Custom Color Mixing	U--	r--	Red
		g--	Green
		b--	Blue
DMX Personalities	3-CH	d001-d512	Selects DMX starting address
	4-CH		
	6-CH		
	7-CH		
	9-CH		
	18-CH		

---

## Configuration (DMX)

Set the product in DMX mode to control with a DMX controller.

1. Connect the product to a suitable power outlet.
2. Turn the product on.
3. Connect a DMX cable from the DMX output of the DMX controller to the DMX input socket on the product.

## DMX Personalities and Starting Address

The COLORband PiX™ Mini has six DMX personalities, from a 3-channel mode for basic control to an 18-channel mode with more advanced control over the lights.

The COLORband PiX™ Mini uses up to 18 DMX channels in its 18-channel DMX mode, which defines the highest configurable address to **495**.

When selecting a starting DMX address, always consider the number of DMX channels the selected DMX mode uses. If you choose a starting address that is too high, you could restrict the access to some of the product's channels.

If you are not familiar with the DMX protocol, download the DMX Primer from [www.chauvetlighting.com](http://www.chauvetlighting.com).

To select the DMX personality, do the following:

1. Press **<MENU>** repeatedly until **3-CH**, **4-CH**, **6-CH**, **7-CH**, **9-CH**, or **18CH** shows on the display.
2. Press **<ENTER>** to choose your DMX personality when it appears on the display.

To then choose your starting address:

1. The display should show **d 1** once you've selected your DMX personality using the steps above.
2. Use **<UP>** or **<DOWN>** to select the starting address.
3. Press **<ENTER>**.

## Sectional Control

The COLORband PiX™ Mini offers sectional control of the lights, anywhere from 2 through 6 sections. To access this, simply choose the DMX personality as shown above.

**Note:** Not all DMX personalities offer sectional control.

## DMX Channel Assignments and Values

7-CH	Channel	Function	Value	Setting
	1	Red	000 ◊ 255	0~100%
	2	Green	000 ◊ 255	0~100%
	3	Blue	000 ◊ 255	0~100%
	4	Color Macros	000 ◊ 015	No function
			016 ◊ 255	Color Macros
	5	Speed	000 ◊ 255	Speed (slow to fast) (when CH.6 is from 032~233)
		Strobe (CH.1-CH.4 only)	000 ◊ 015	No function
			016 ◊ 255	0~30 Hz
	6	Auto Programs	000 ◊ 031	No function
			032 ◊ 063	Pulse effect 0~100%
			064 ◊ 095	Pulse effect 100%~0
			096 ◊ 114	Pulse effect 100%~0~100%
			115 ◊ 127	Chase program
			128 ◊ 159	Auto fade transition
			160 ◊ 191	Auto snap transition (3 colors)
			192 ◊ 223	Auto snap transition (7 colors)
			224 ◊ 255	Sound-Active mode
	7	Dimmer	000 ◊ 255	0~100%

3-CH	Channel	Function	Value	Setting
	1	Red	000 ◊ 255	0~100%
	2	Green	000 ◊ 255	0~100%
	3	Blue	000 ◊ 255	0~100%

4-CH	Channel	Function	Value	Setting
	1	Red	000 ◊ 255	0~100%
	2	Green	000 ◊ 255	0~100%
	3	Blue	000 ◊ 255	0~100%
	4	Dimmer	000 ◊ 255	0~100%

6-CH	Channel	Function	Value	Setting	Section
	1	Red	000 ◊ 255	0~100%	1
	2	Green	000 ◊ 255	0~100%	
	3	Blue	000 ◊ 255	0~100%	
	4	Red	000 ◊ 255	0~100%	2
	5	Green	000 ◊ 255	0~100%	
	6	Blue	000 ◊ 255	0~100%	

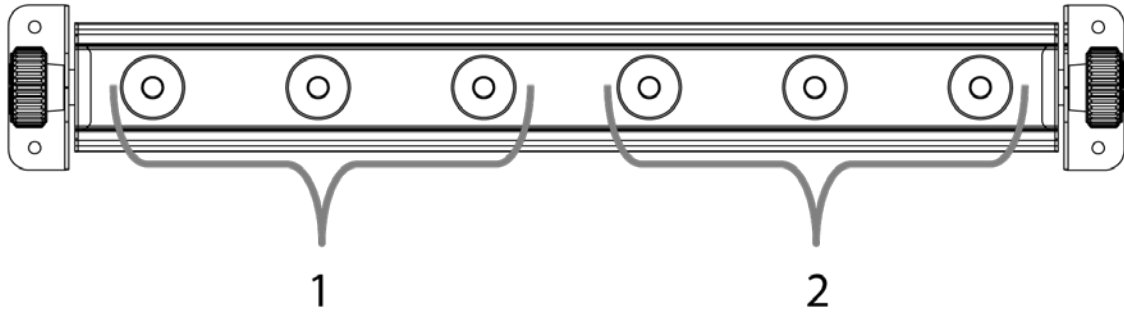

9-CH	Channel	Function	Value	Setting	Section
	1	Red	000 ◊ 255	0~100%	1
	2	Green	000 ◊ 255	0~100%	
	3	Blue	000 ◊ 255	0~100%	
	4	Red	000 ◊ 255	0~100%	2
	5	Green	000 ◊ 255	0~100%	
	6	Blue	000 ◊ 255	0~100%	
	7	Red	000 ◊ 255	0~100%	3
	8	Green	000 ◊ 255	0~100%	
	9	Blue	000 ◊ 255	0~100%	

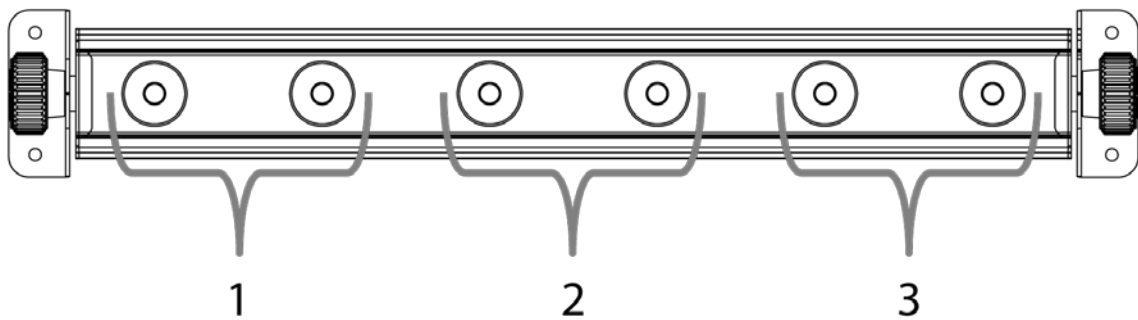

18CH	Channel	Function	Value	Setting	Section
	1	Red	000 ◊ 255	0~100%	1
	2	Green	000 ◊ 255	0~100%	
	3	Blue	000 ◊ 255	0~100%	
	4	Red	000 ◊ 255	0~100%	2
	5	Green	000 ◊ 255	0~100%	
	6	Blue	000 ◊ 255	0~100%	
	7	Red	000 ◊ 255	0~100%	3
	8	Green	000 ◊ 255	0~100%	
	9	Blue	000 ◊ 255	0~100%	
	10	Red	000 ◊ 255	0~100%	4
	11	Green	000 ◊ 255	0~100%	
	12	Blue	000 ◊ 255	0~100%	
	13	Red	000 ◊ 255	0~100%	5
	14	Green	000 ◊ 255	0~100%	
	15	Blue	000 ◊ 255	0~100%	
	16	Red	000 ◊ 255	0~100%	6
	17	Green	000 ◊ 255	0~100%	
	18	Blue	000 ◊ 255	0~100%	

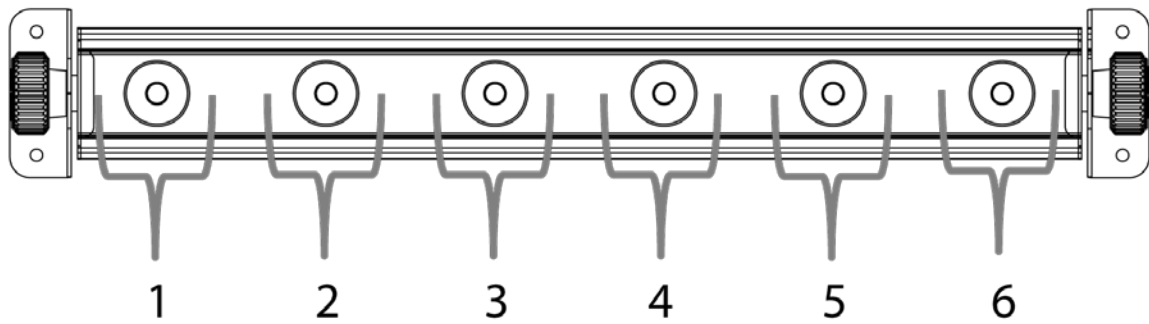

---

## Configuration (Standalone)

Set the product in one of the standalone modes to control without a DMX controller.

1. Connect the product to a suitable power outlet.
2. Turn the product on.



**Never connect a product that is operating in any standalone mode (either Static, Automatic, or Sound) to a DMX string connected to a DMX controller. Products in standalone mode may transmit DMX signals that could interfere with the DMX signals from the controller.**

### Static Color Mode

To enable the Static Color Mode, do the following:

1. Press **<MENU>** repeatedly until **C--** shows on the display.
2. Press **<ENTER>**.
3. Use **<UP>** or **<DOWN>** to choose a color (**C1-C7**).
4. Press **<ENTER>**.

### Automatic Mode

To enable the Automatic Mode, follow the instructions below:

1. Press **<MENU>** repeatedly until **P--** shows on the display.
2. Press **<ENTER>**.
3. Use **<UP>** or **<DOWN>** to choose your auto program (**P1-P7**).
4. Press **<ENTER>**.

You can adjust the speed of the automatic program as well.

1. Press **<MENU>** repeatedly until **S--** shows on the display.
2. Press **<ENTER>**.
3. Use **<UP>** or **<DOWN>** to adjust the duration of each step of the automatic program from **S001** (slow) to **S100** (fast).
4. Press **<ENTER>**.

### Custom Static Color Mode

To enable the Custom Static Color Mode, follow the instructions below:

1. Press **<MENU>** repeatedly until **U--** shows on the display.
2. Press **<ENTER>**.
3. Press **<UP>** or **<DOWN>** to choose between colors (**r--**, **g--**, **b--**).
4. Press **<ENTER>**.
5. Press **<UP>** or **<DOWN>** to choose the intensity of the color (**000-100**).
6. Repeat the steps to mix additional colors to create the color you need.
7. Press **<ENTER>**.



---

## Master/Slave Mode

The Master/Slave mode allows a single COLORband PiX™ Mini unit (the “master”) to control the actions of one or more COLORband PiX™ Mini units (the “slaves”) without the need of a DMX controller. The master unit will be set to operate in either Automatic or Sound Active mode, while the slave units will be set to operate in Slave Mode. Once set and connected, the slave units will operate in unison with the master unit.

Configure the units as indicated below.

### Slave units:

1. Press **<MODE>** repeatedly until **SLA** shows on the display.
2. Press **<ENTER>** to accept.
3. Set the DMX address to **001**.
4. Connect the DMX input of the first slave unit to the DMX output of the master unit.
5. Connect the DMX input of the subsequent slave units to the DMX output of the previous slave unit.
6. Finish setting and connecting all the slave units.

### Master unit:

1. Set the master unit to operate in either Automatic or Sound mode.
2. Make the master unit the first unit in the DMX daisy chain.

### Advanced Master/Slave options for using the COLORband PiX™ as master unit with the COLORband PiX™ Mini:

When a COLORband PiX™ is the master unit and COLORband PiX™ Minis are slave units, the submenu **A1~A126** (found under **SLA** in the master unit) will select how many slave units are attached to it. Selecting **A A1** or **A A2** on the COLORband PiX™ Minis will tell the master unit which side of the strip the Minis are on. The combination of number and direction settings allows lots of variation, including allowing 2 COLORband PiX™ Minis to appear as one single strip the same size as the master COLORband PiX™ for uninterrupted chases.

### Advanced Master/Slave options for using the COLORband PiX™ Mini as master unit with the COLORband PiX™:

When a COLORband PiX™ Mini is the master unit and COLORband PiX™ serves as a slave, selecting **A A1** or **A A2** on the COLORband PiX™ Minis will command the COLORband PiX™ to either light LED-for-LED with the Mini (meaning half of the COLORband PiX™), or to light up entirely at the same speed.



- **Configure all the slave units before connecting the master unit to the DMX daisy chain.**
- **Never connect a DMX controller to a DMX string configured for Master/Slave operation because the controller may interfere with the signals from the master unit.**
- **Do not connect more than 31 slave units to the master unit.**

---

## 5. MAINTENANCE

### **Product Maintenance**

Dust build-up reduces light output performance and can cause overheating. This can lead to reduction of the light source's life. To maintain optimum performance and minimize wear, clean lighting products at least twice a month. However, usage and environmental conditions could be contributing factors to increase the cleaning frequency.

To clean the product, follow the instructions below:

- Unplug the product from power.
- Wait until the product is at room temperature.
- Use a vacuum (or dry compressed air) and a soft brush to remove dust collected on the external surface/vents.
- Clean all transparent surfaces with a mild soap solution, ammonia-free glass cleaner, or isopropyl alcohol.
- Apply the solution directly to a soft, lint-free cotton cloth or a lens cleaning tissue.
- Carefully wipe any dirt or grime to the outside edge of the transparent surface.
- Gently polish the transparent surfaces until they are free of haze and lint.



**Always dry the transparent surfaces carefully after cleaning them.**

---

In case you need to return a product or request support:

- If you live in the U.S., contact CHAUVET® World Headquarters (see below).
- If you live in the UK or Ireland, contact CHAUVET® Europe Ltd.(see below).
- If you live in any other country, DO NOT contact CHAUVET®. Instead, contact your distributor of record. Refer to our website for contact details of distributors outside the U.S., United Kingdom, or Ireland.

## Contact Us

### World Headquarters

CHAUVET®

#### General Information

Address: 5200 NW 108th Avenue  
Sunrise, FL 33351  
Voice: (954) 577-4455  
Fax: (954) 929-5560  
Toll free: (800) 762-1084

#### Technical Support

Voice: (954) 577-4455 (Press 4)  
Fax: (954) 756-8015  
Email: [tech@chauvetlighting.com](mailto:tech@chauvetlighting.com)

#### World Wide Web

[www.chauvetlighting.com](http://www.chauvetlighting.com)

### United Kingdom & Ireland

CHAUVET® Europe Ltd.

#### General Information

Address: Unit 1C  
Brookhill Road Industrial Estate  
Pinxton, Nottingham, UK  
NG16 6NT  
Voice: +44 (0)1773 511115  
Fax: +44 (0)1773 511110

#### Technical Support

Email: [uktech@chauvetlighting.com](mailto:uktech@chauvetlighting.com)

#### World Wide Web

[www.chauvetlighting.co.uk](http://www.chauvetlighting.co.uk)



**If you live outside the U.S., United Kingdom, or Ireland, contact your distributor of record and follow their instructions on how to return CHAUVET® products to them. Visit our website for contact details.**

## Returns

Call the corresponding CHAUVET® Tech Support office and request a Return Merchandise Authorization (RMA) number before shipping the product. Be prepared to provide the model number, serial number, and a brief description of the cause for the return.

You must send the merchandise prepaid, in its original box, and with its original packing and accessories. CHAUVET® will not issue call tags.

Clearly label the package with the RMA number. CHAUVET® will refuse any product returned without an RMA number.



**Write the RMA number on a properly affixed label. DO NOT write the RMA number directly on the box.**

Before sending the product, clearly write the following information on a piece of paper and place it inside the box:

- Your name
- Your address
- Your phone number
- RMA number
- A brief description of the problem

Be sure to pack the product properly. Any shipping damage resulting from inadequate packaging will be your responsibility. FedEx packing or double-boxing are recommended.



**CHAUVET® reserves the right to use its own discretion to repair or replace returned product(s).**

## 6. TECHNICAL SPECIFICATIONS

<b>Dimensions and Weight</b>	<b>Length</b>	<b>Width</b>	<b>Height</b>	<b>Weight</b>
	21.8 in (554 mm)	2.5 in (64 mm)	6.1 in (154 mm)	4.9 lbs (2.2 kg)
<b>Note:</b> Dimensions in inches rounded to the nearest decimal digit.				
<b>Power</b>	<b>Power Supply Type</b>	<b>Range</b>	<b>Voltage Selection</b>	
	Switching (internal)	100~240 V, 50/60 Hz	Auto-ranging	
	<b>Parameter</b>	<b>120 V, 60 Hz</b>	<b>230 V, 50 Hz</b>	
	Consumption	47 W	51 W	
	Operating	0.4 A	0.2 A	
<b>Power I/O</b>	<b>Power I/O</b>	<b>US/Worldwide</b>	<b>UK/Europe</b>	
	Power input connector	IEC	IEC	
	Power output connector	Edison	IEC	
	Power Cord plug	Edison (US)	Local plug	
<b>Light Source</b>	<b>Type</b>	<b>Power</b>	<b>Lifespan</b>	
	LED	3 W	50,000 hours	
<b>Photo Optic</b>	<b>Color</b>	<b>Quantity</b>	<b>Current</b>	
	Tri-color	6	350 mA	
	<b>Parameter</b>			
	Strobe Rate	0~30 Hz		
	Illuminance @ 2 m	1,300 lux		
	Beam angle	19°		
	Field angle	35°		
<b>Thermal</b>	<b>Maximum External Temp.</b>	<b>Cooling System</b>		
	104° F (40° C)	Convection		
<b>DMX</b>	<b>I/O Connectors</b>	<b>Connector Type</b>	<b>Channel Range</b>	
	3-pin and 5-pin XLR	Sockets	3, 4, 6, 7, 9, 18	
<b>Ordering</b>	<b>Product Name</b>	<b>Item Code</b>	<b>Item Number</b>	
	COLORband PiX™ Mini	03020470	COLORBANDPIXMINI	



UL 1573  
CSA C22.2 No. 166  
E113093



RoHS

